

REVISION RECORD			
LTR	ECO NO.	APPROVED:	DATE:

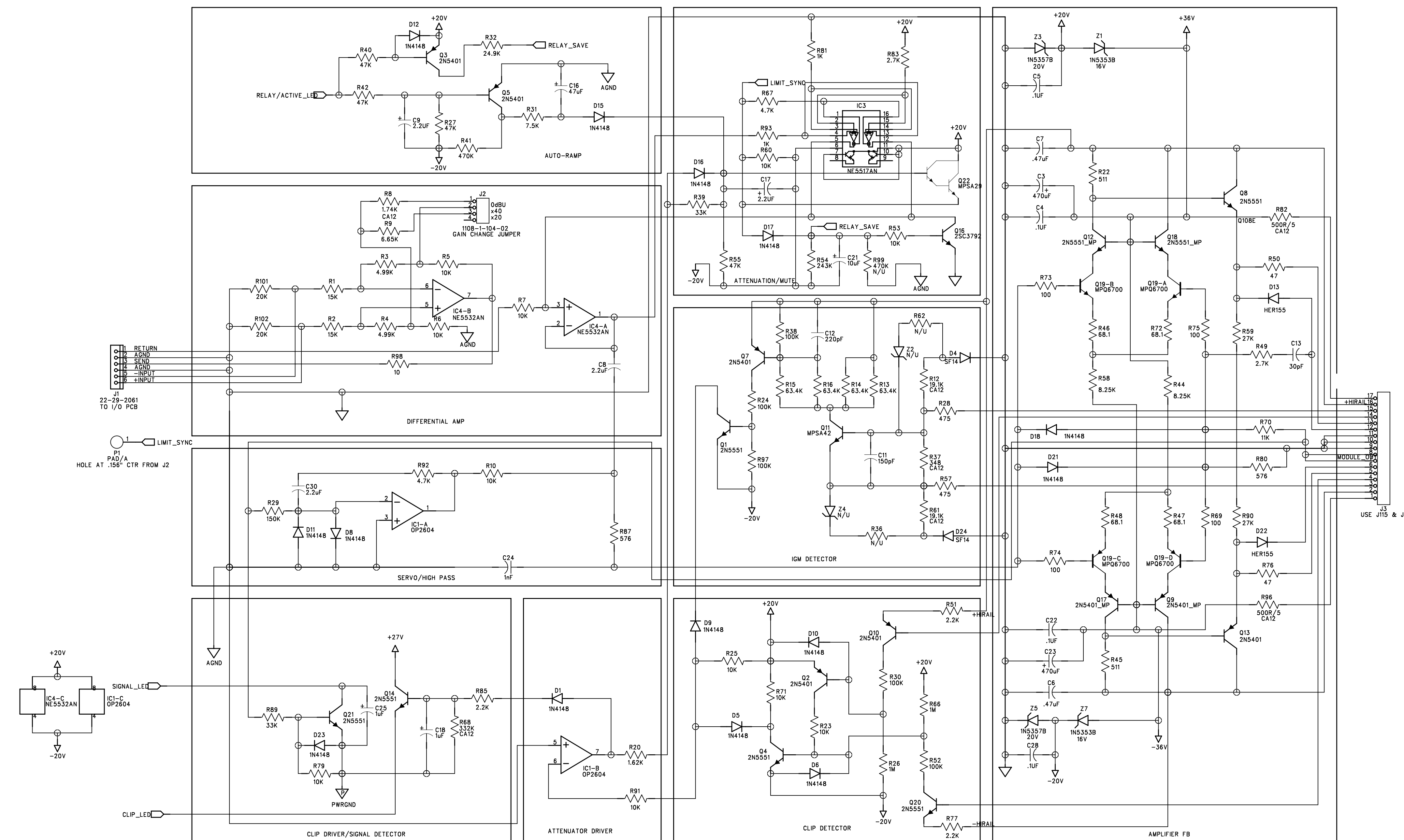

- 2/12/96 ADDED CONNECTION BETWEEN R40/R42 AND Q6 COLLECTOR.
- 2/21/96 D4, D24, R12, R61 ADDED TO CA6, CA9 VIA ECO'S 1068,1120
- 2/21/96 CHANGED R101, R102, R8, R9, R1-R4 VIA ECO #'S 1069,1070,1071
- 5/8/96 CHANGED R68 TO 332K
- 05/29/96 MODIFIED OTA CKT, ADDED Q22.

NOTES:
 SCHEMATIC DRAWN FOR CA-12 PRE-AMP.
 ALTERNATE PARTS FOR CA-6 & CA-9 ON PAGE 2.

CRESTAUDIO

TITLE: CA6, CA9, CA12 PREAMP

CODE:	SIZE:	21D2689-04	REV:
			4

SCALE: SHEET: 1 OF 2

REVISION RECORD			
LTR	ECO NO:	APPROVED:	DATE:

D

D

C

C

B

B

A

A

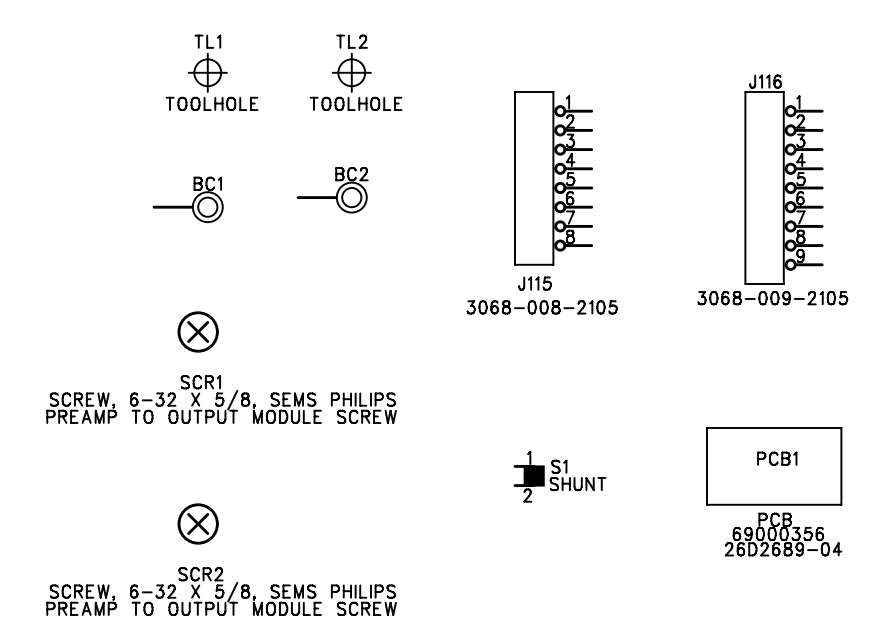
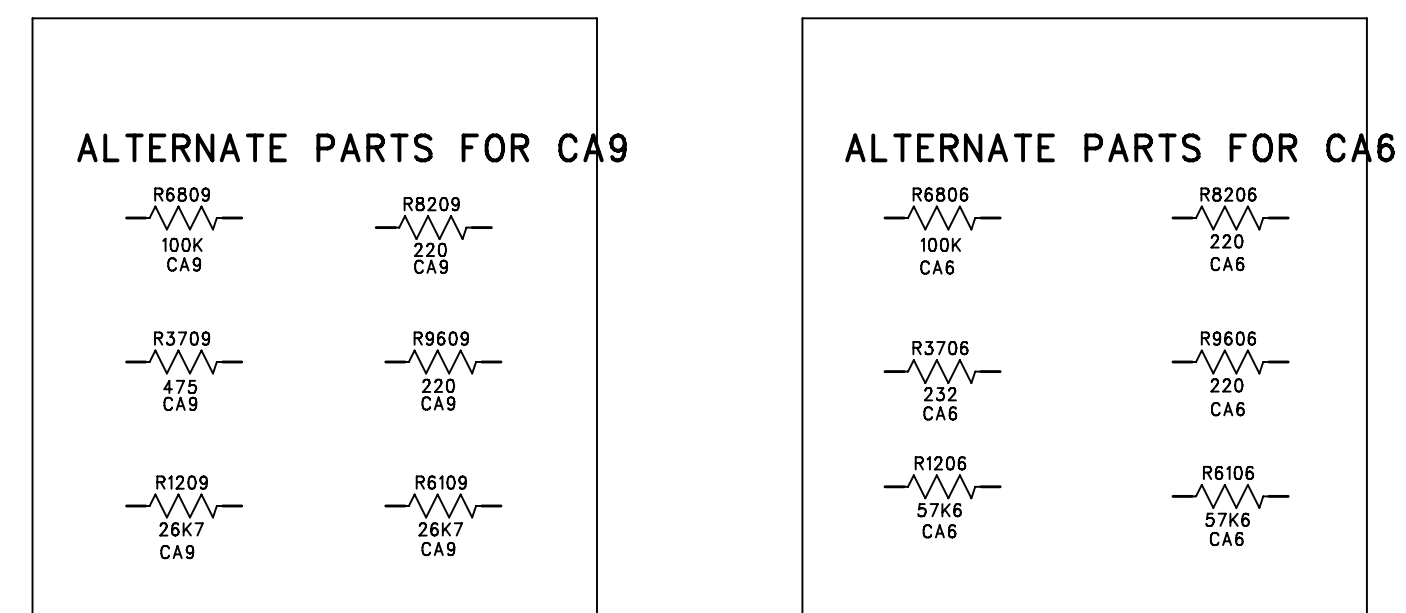
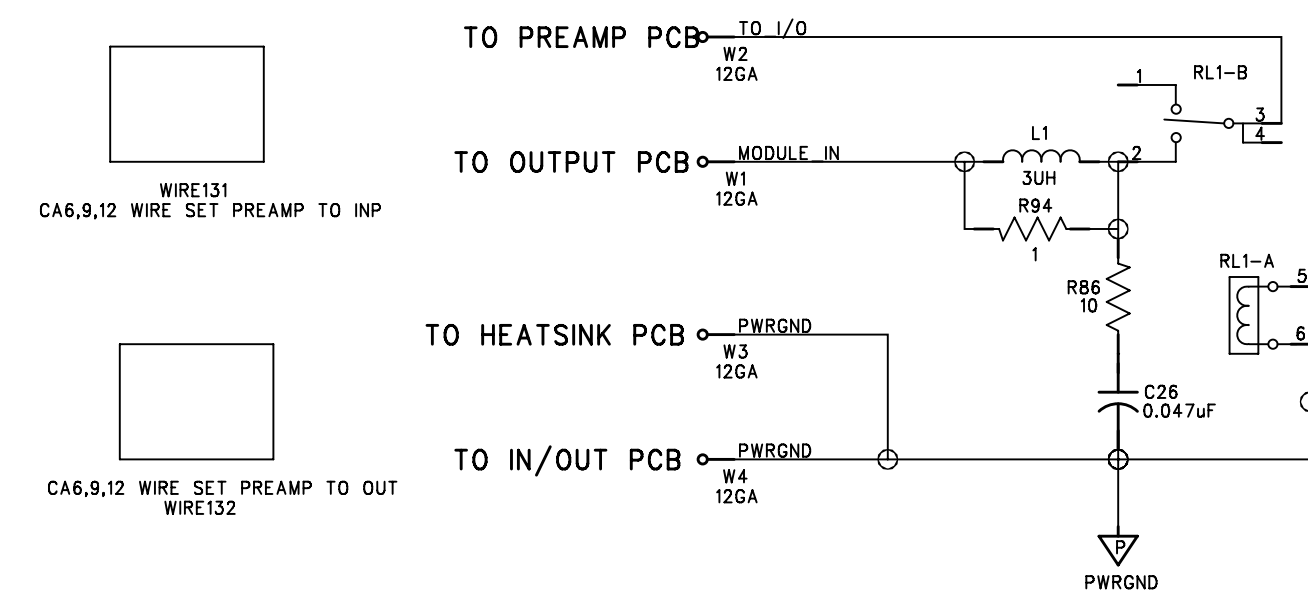
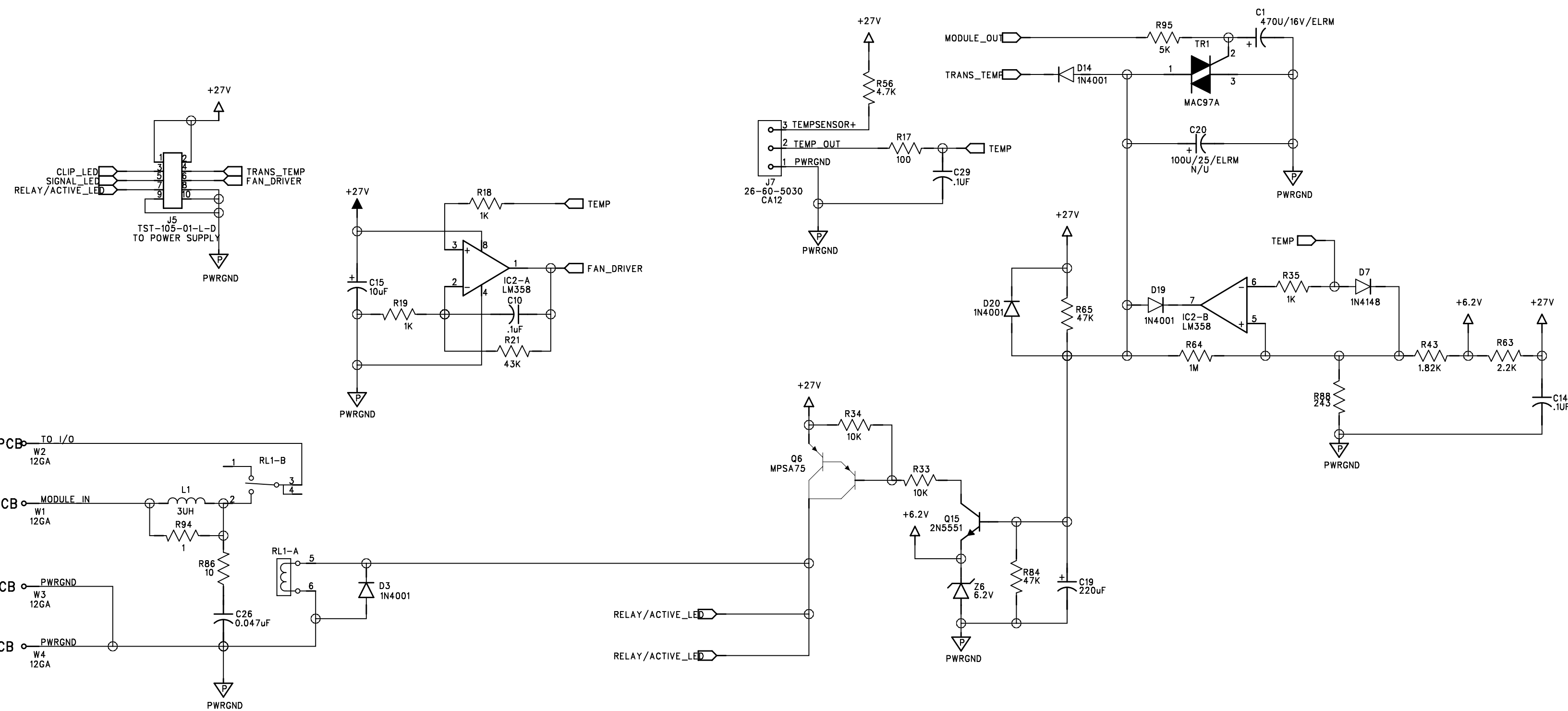

CREST AUDIO

TITLE: CA 6, 9, & 12 PREAMP

CODE:	SIZE:	TITLE:	REV:
		21D2689-04	4

SCALE: SHEET: 2 OF 2